

F:\Clients\0280 Discount Tire\Drawings\C13-PAV DET.dwg Nov 05, 2008-9:59am Terra Associates Inc., damb

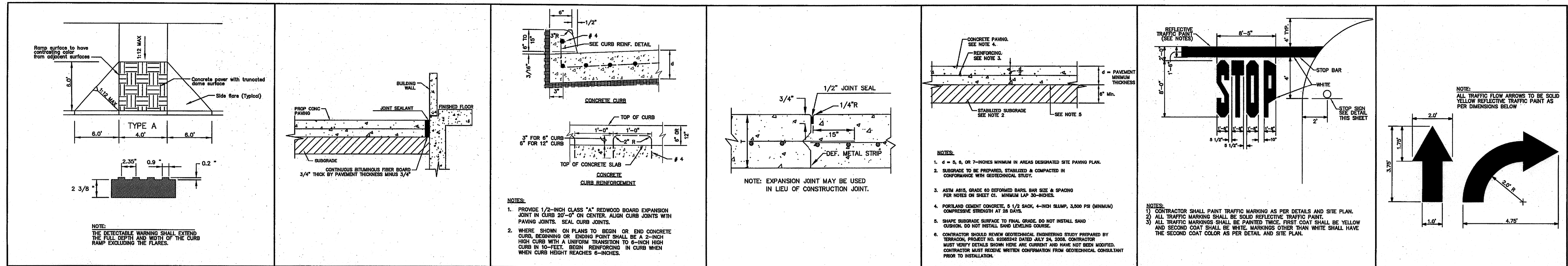

TRUNCATED DOME PATTERN CURB RAMP DETAIL No. 203 PAVING ISOLATION JOINT AT BUILDING No. 142 CONC. CURB & CURB REINFORCEMENT No. 137 CONCRETE PAVING CONSTRUCTION JOINT No. 133 TYPICAL SECTION CONCRETE PAVING No. 129 STOP BAR DETAIL No. 112 TRAFFIC FLOW ARROW No. 104

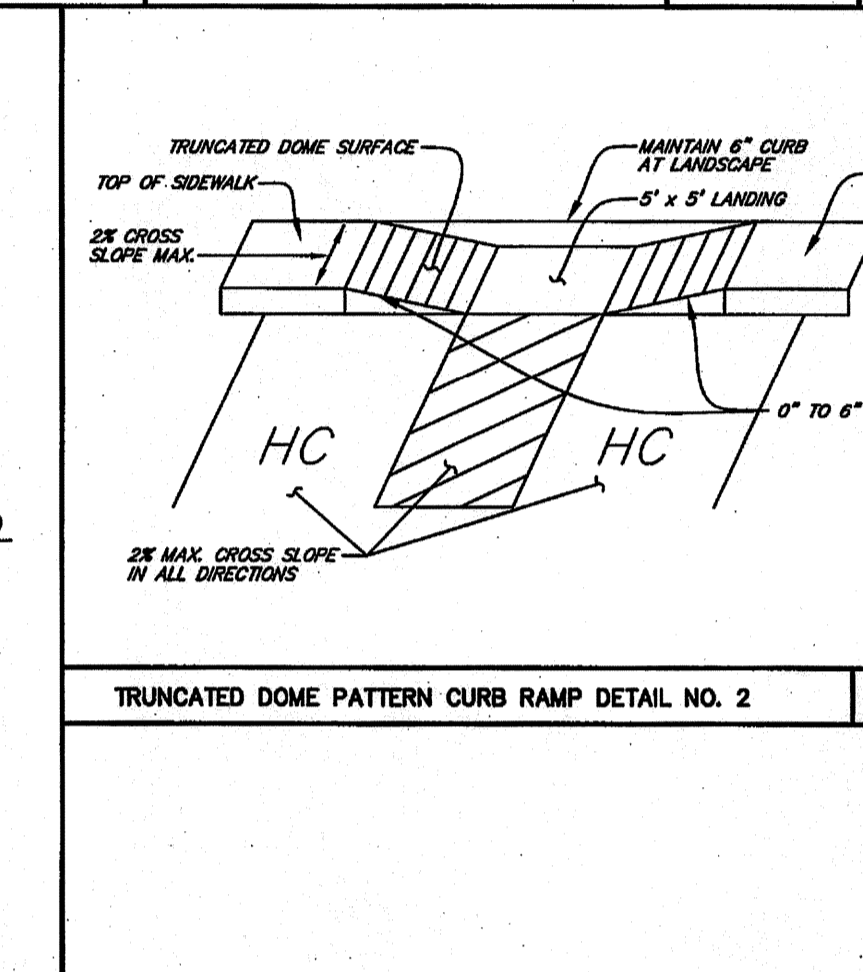
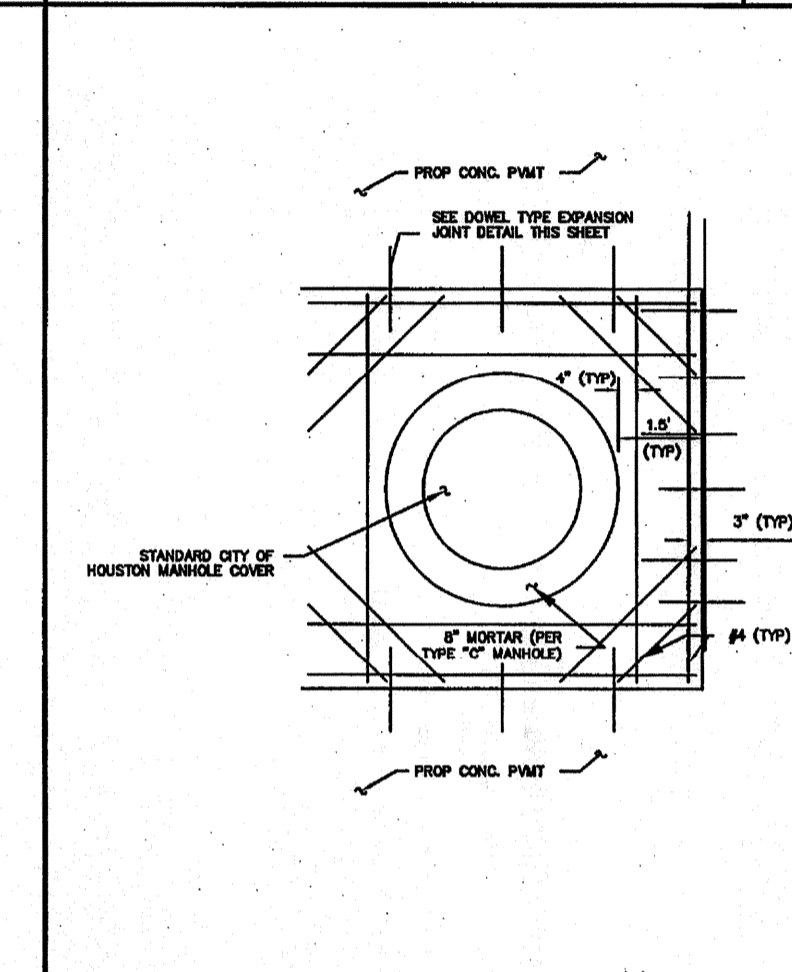
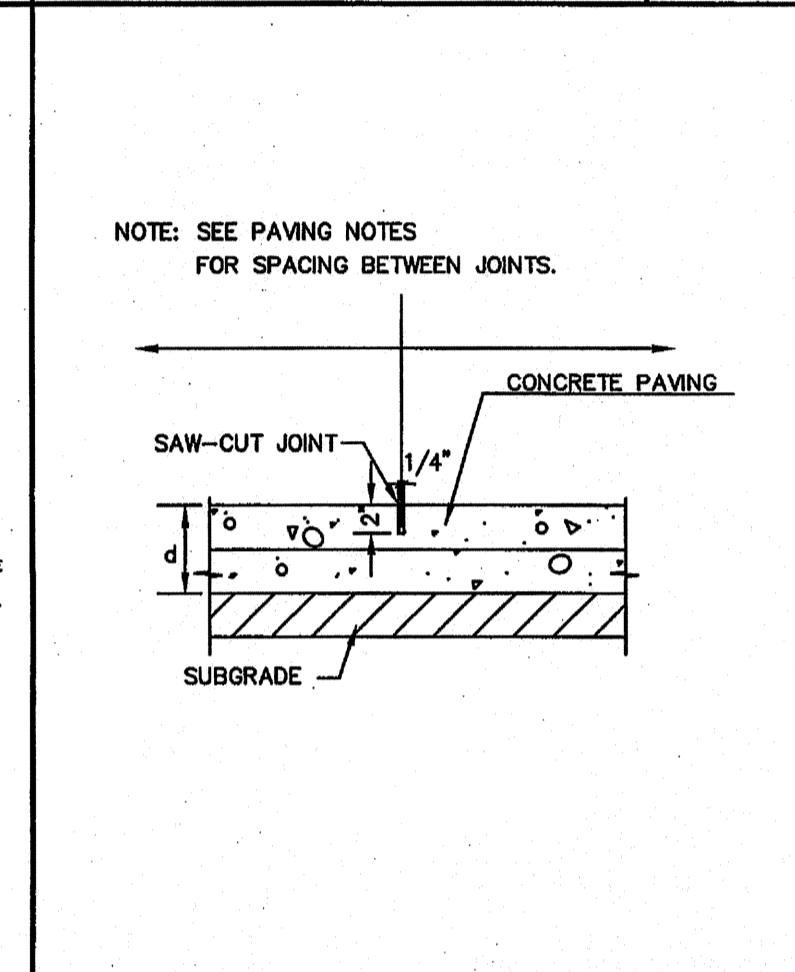
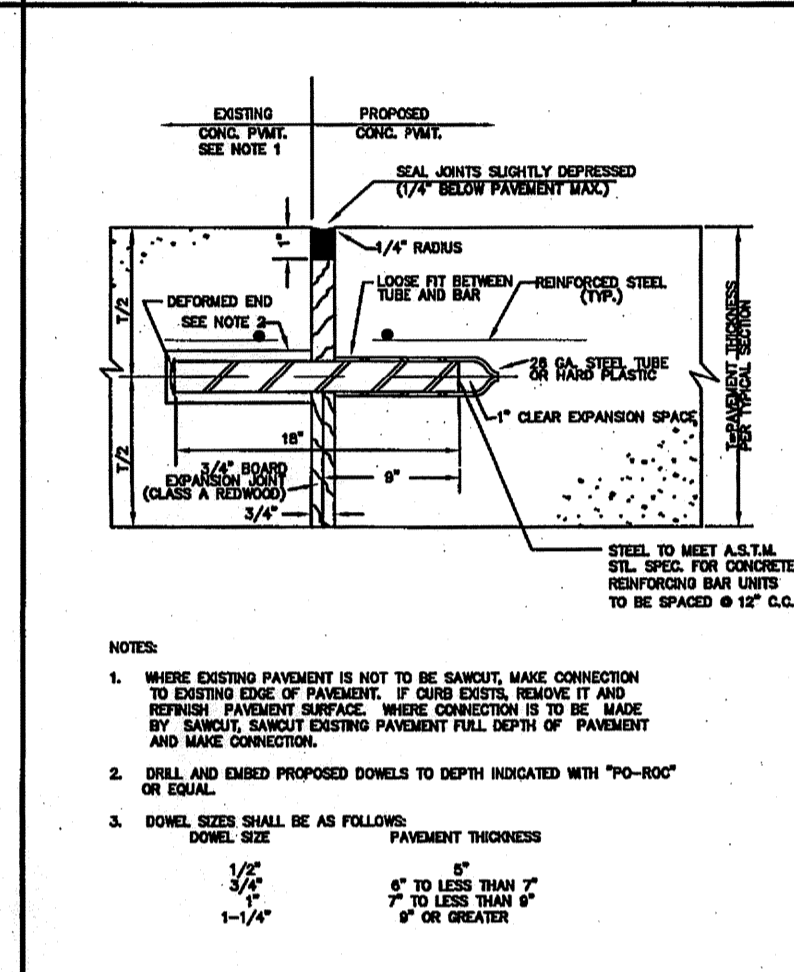
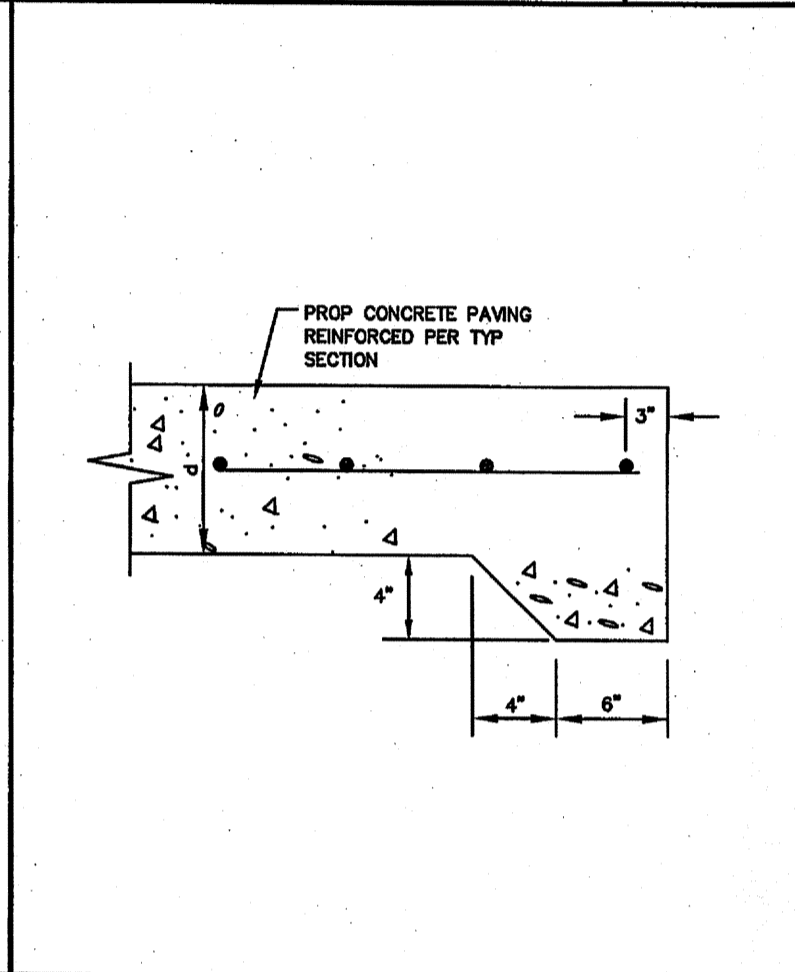
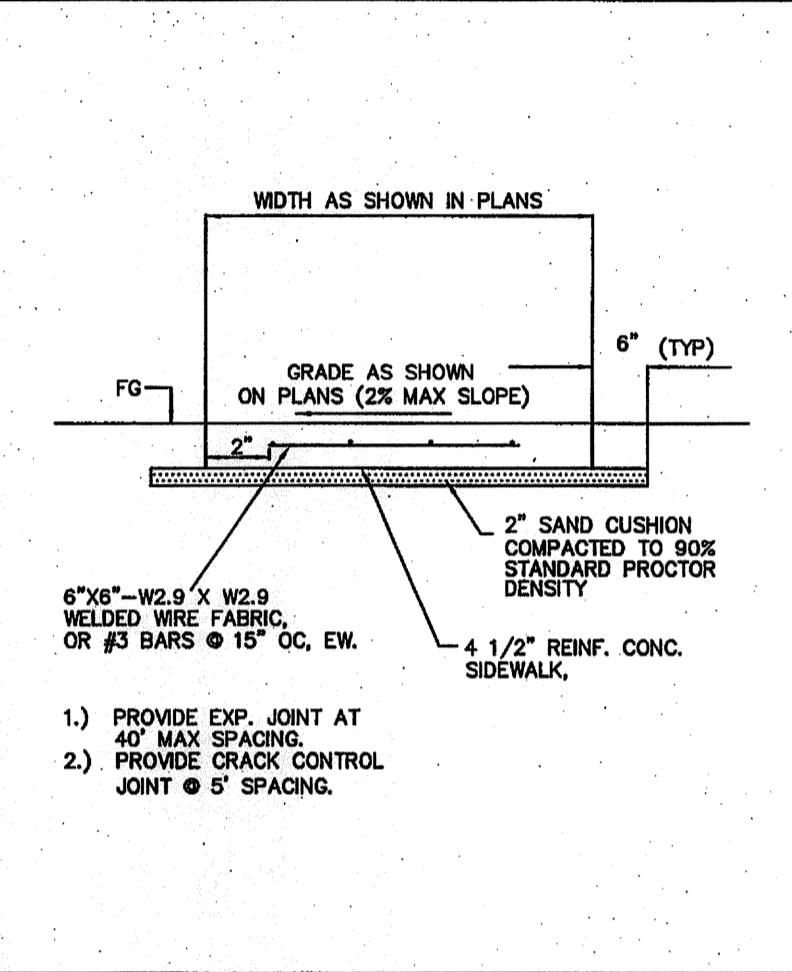
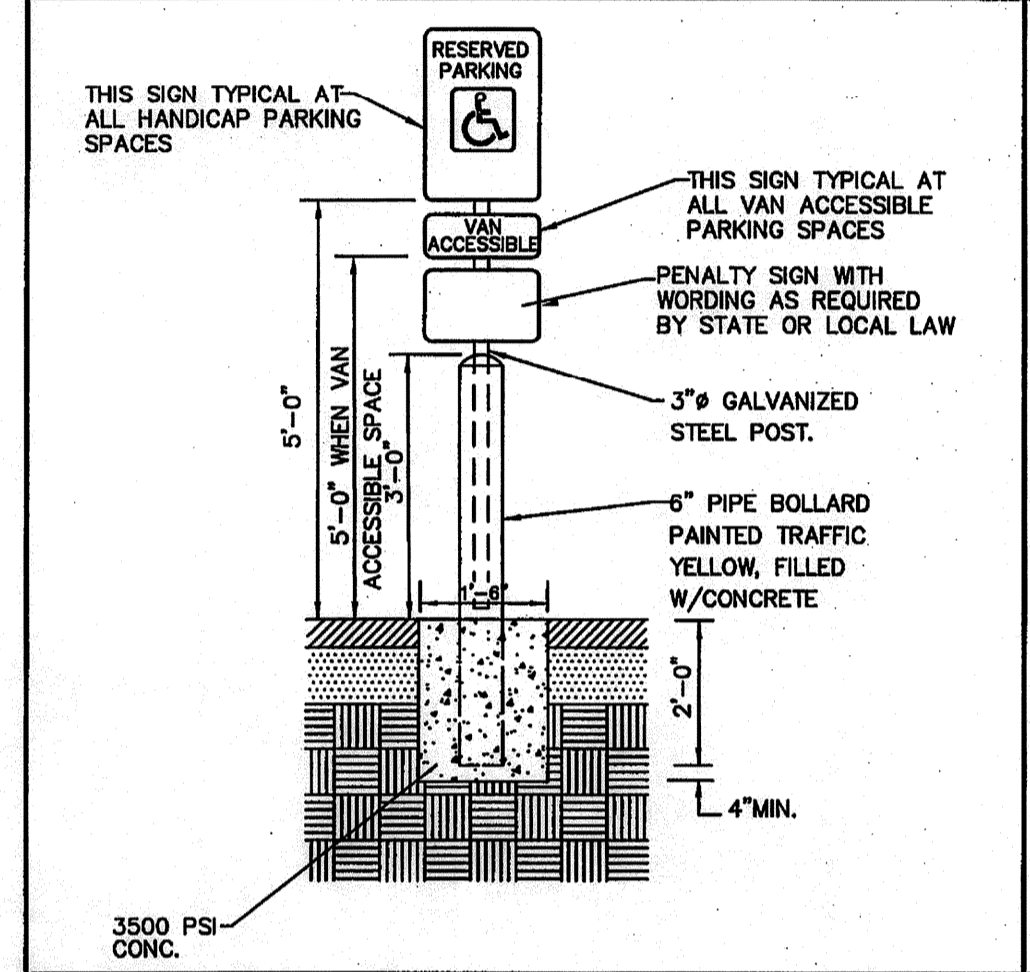

HANDICAP SIGN DETAIL No. 109 DETAILS FOR ON SITE SIDEWALKS No. 168

STANDARD PAVING HEADER No. 141 DOWELED JOINT CONNECTION TO EXISTING PAVEMENT No. 136

CONCRETE PAVING CRACK CONTROL JOINT No. 132 SANITARY SEWER BLOCKOUT DETAIL No. 200

TRUNCATED DOME PATTERN CURB RAMP DETAIL NO. 2 No. 203-A

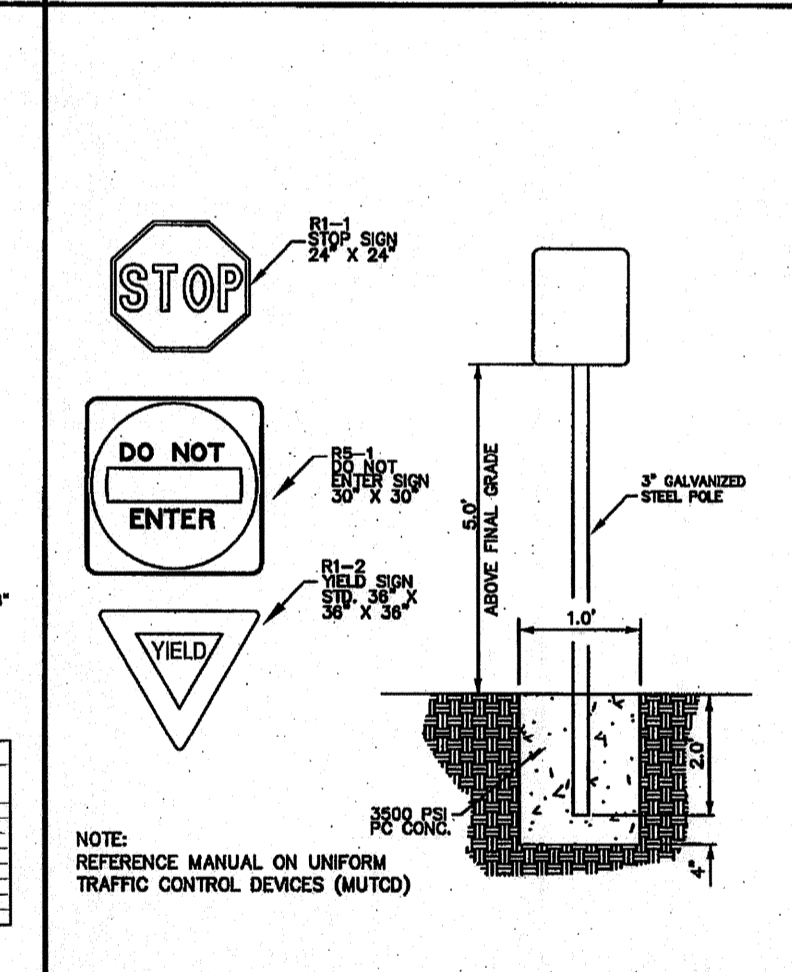
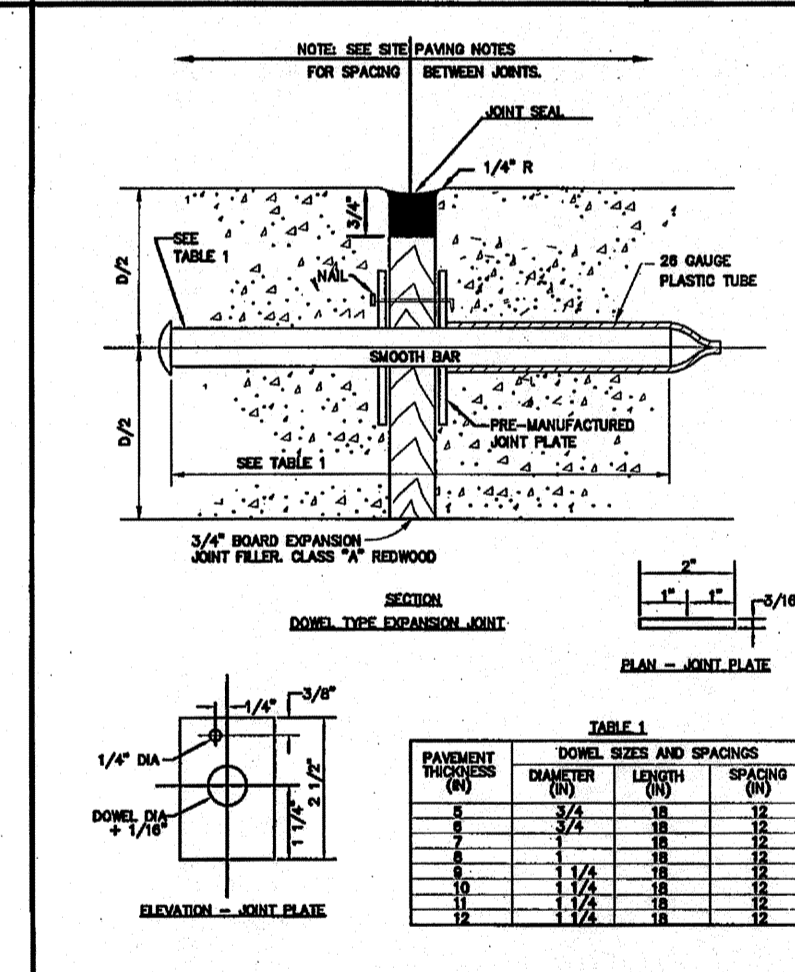
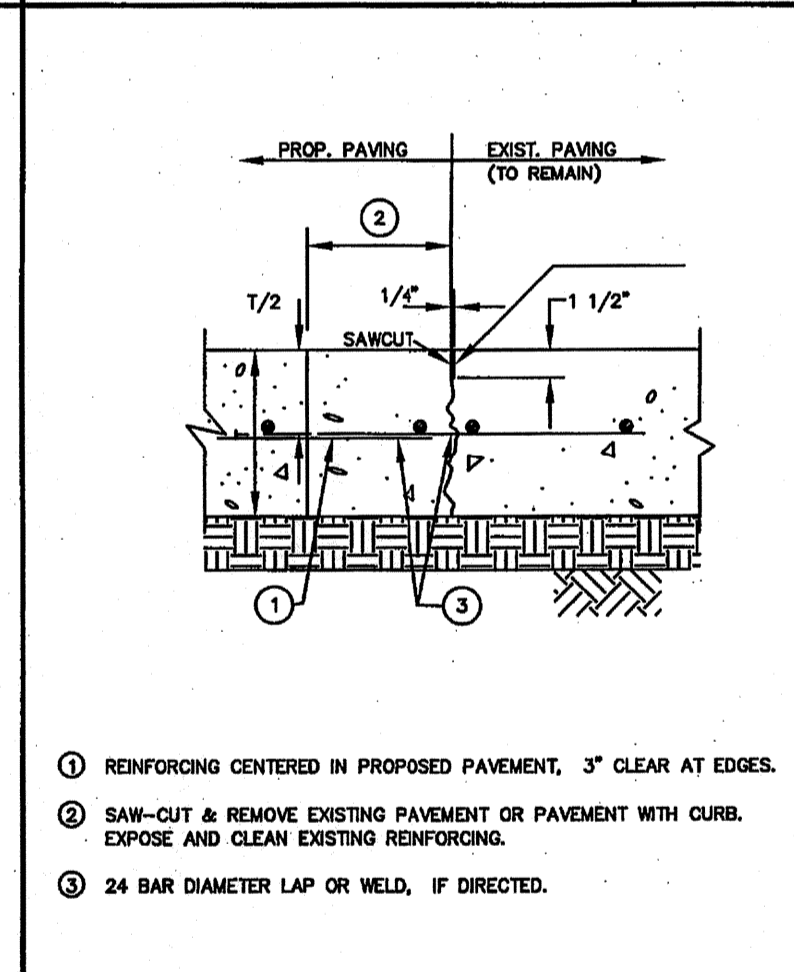
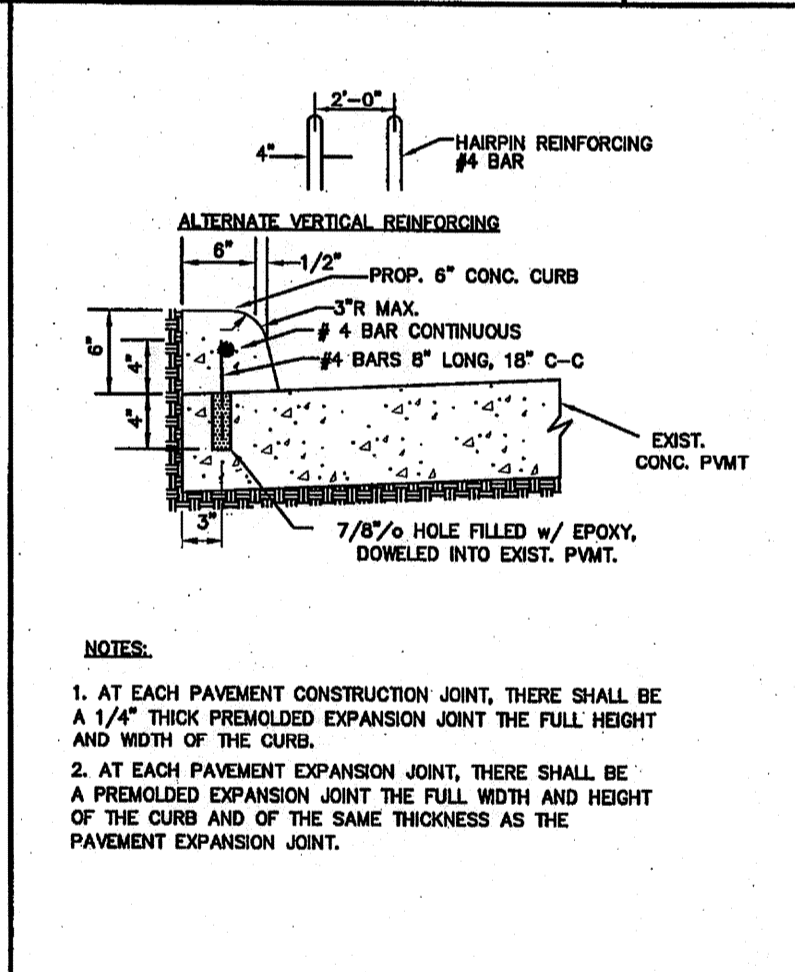
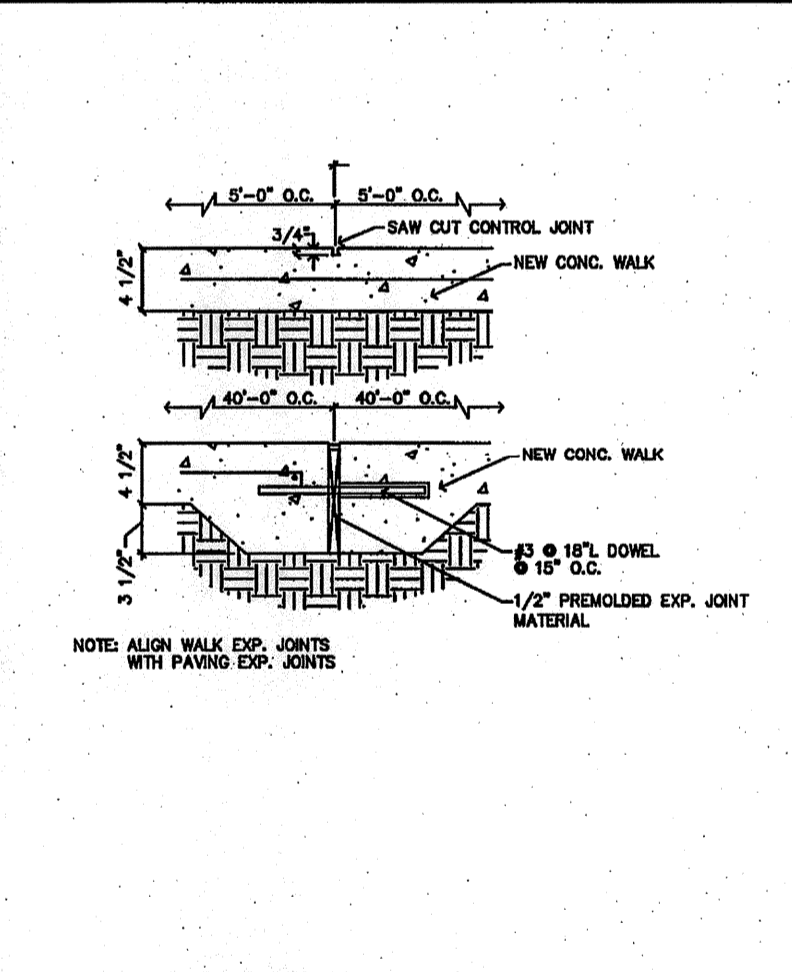
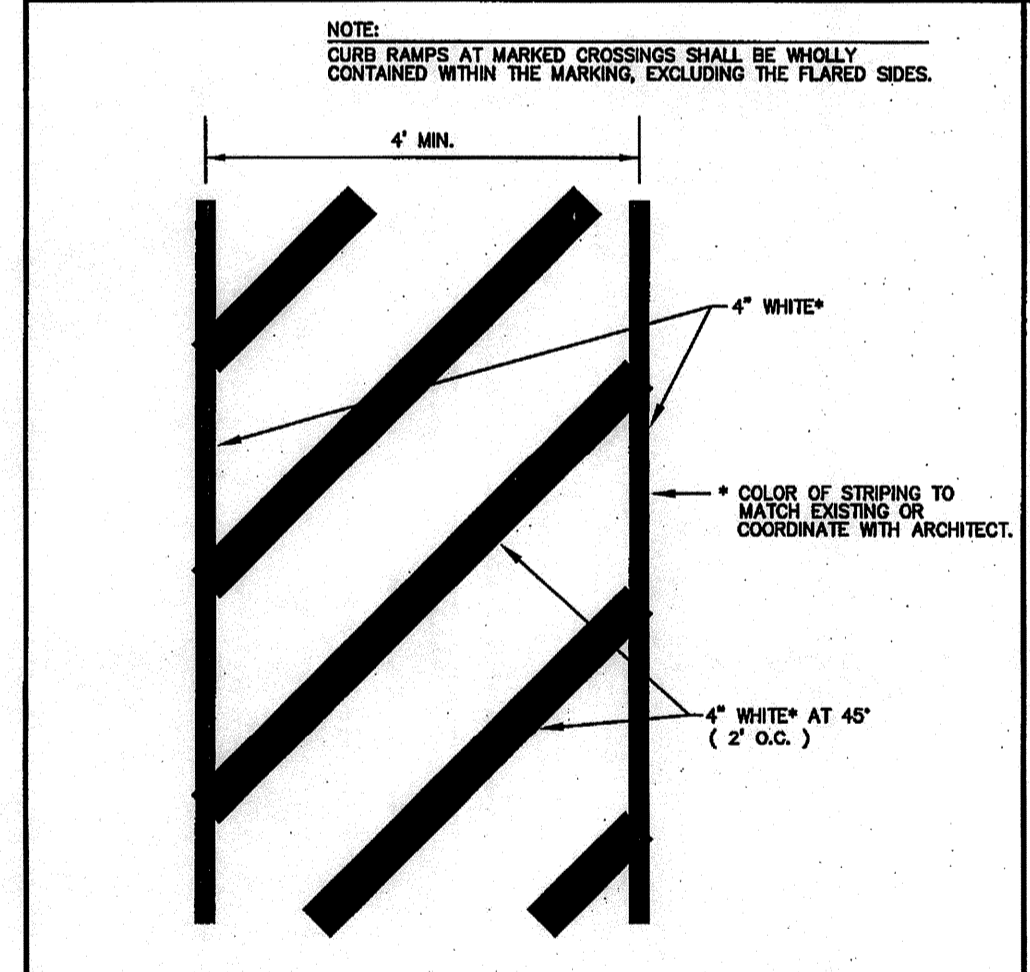

CROSSWALK DETAIL No. 103 SIDE WALK CONTROL & EXP. JOINT No. 167

CONCRETE DOWELED ON CURB FOR CONCRETE PAVEMENT No. 139 CONCRETE TO CONCRETE STANDARD PAVEMENT TIE - IN No. 135

EXPANSION JOINT DETAIL No. 131 SIGN DETAILS No. 111

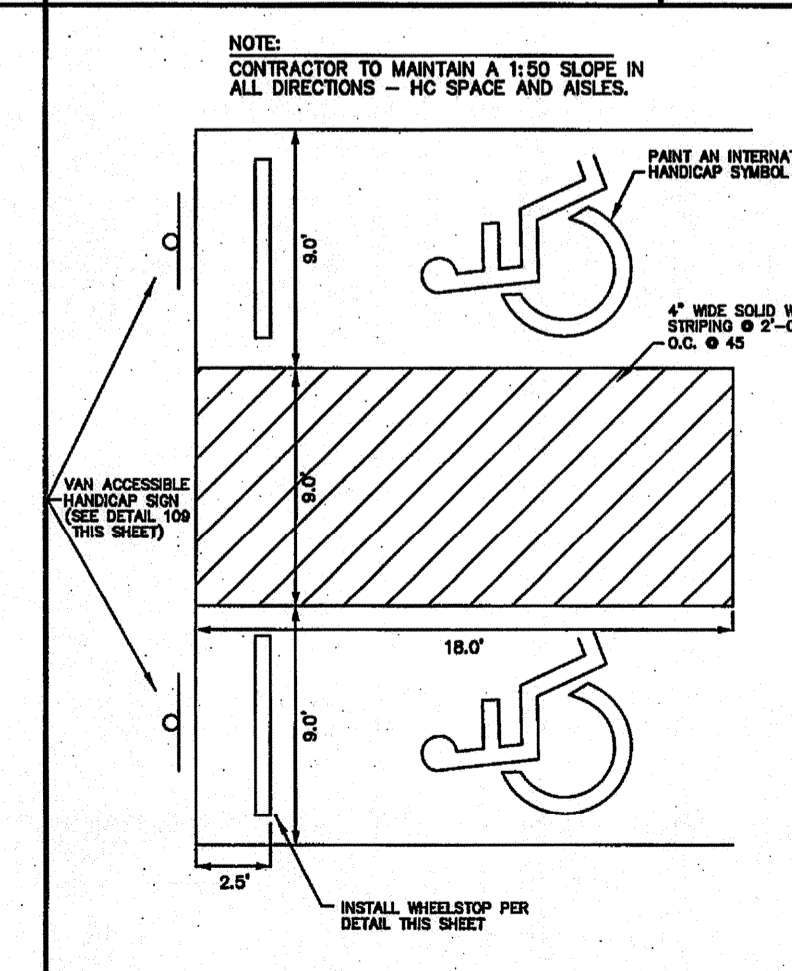
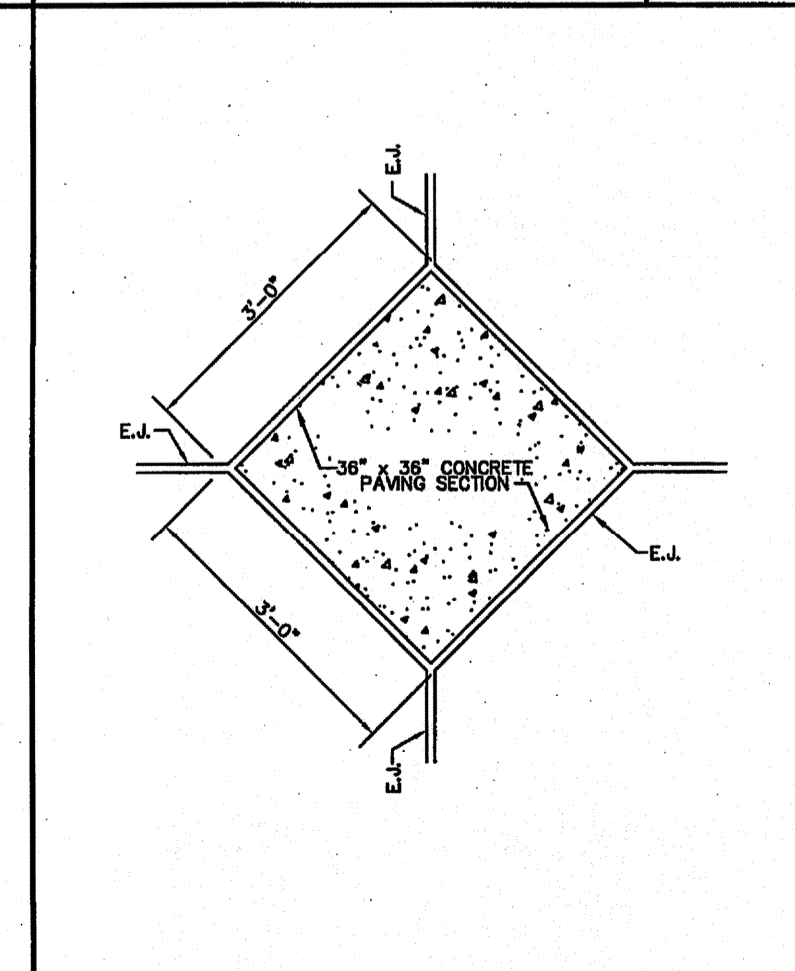
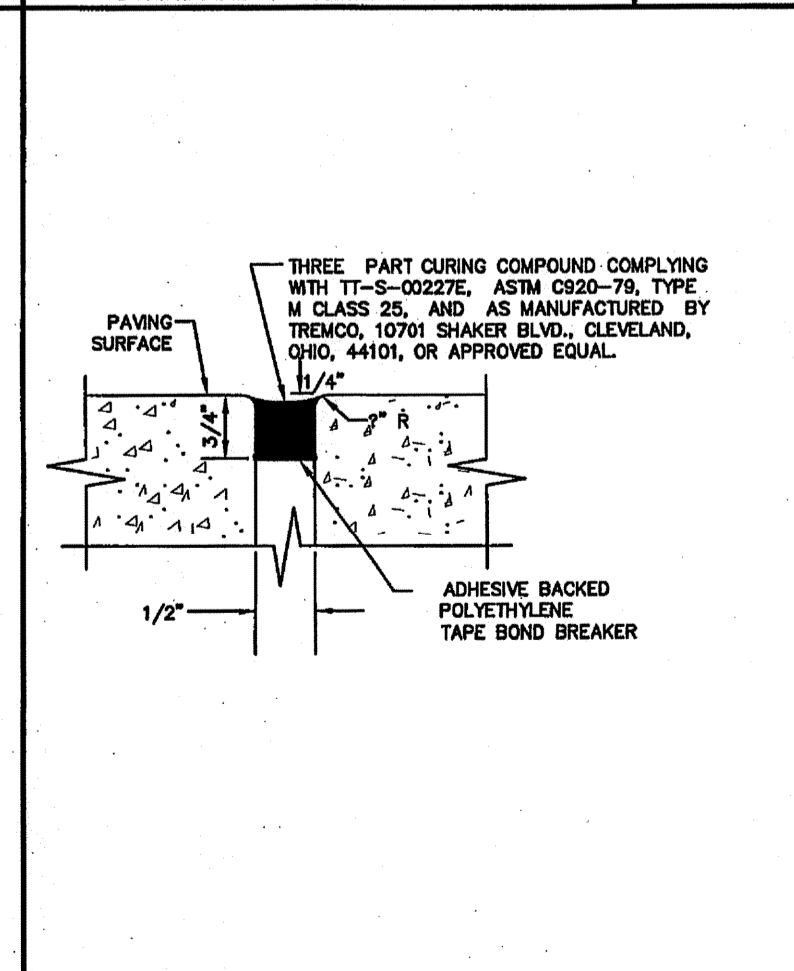
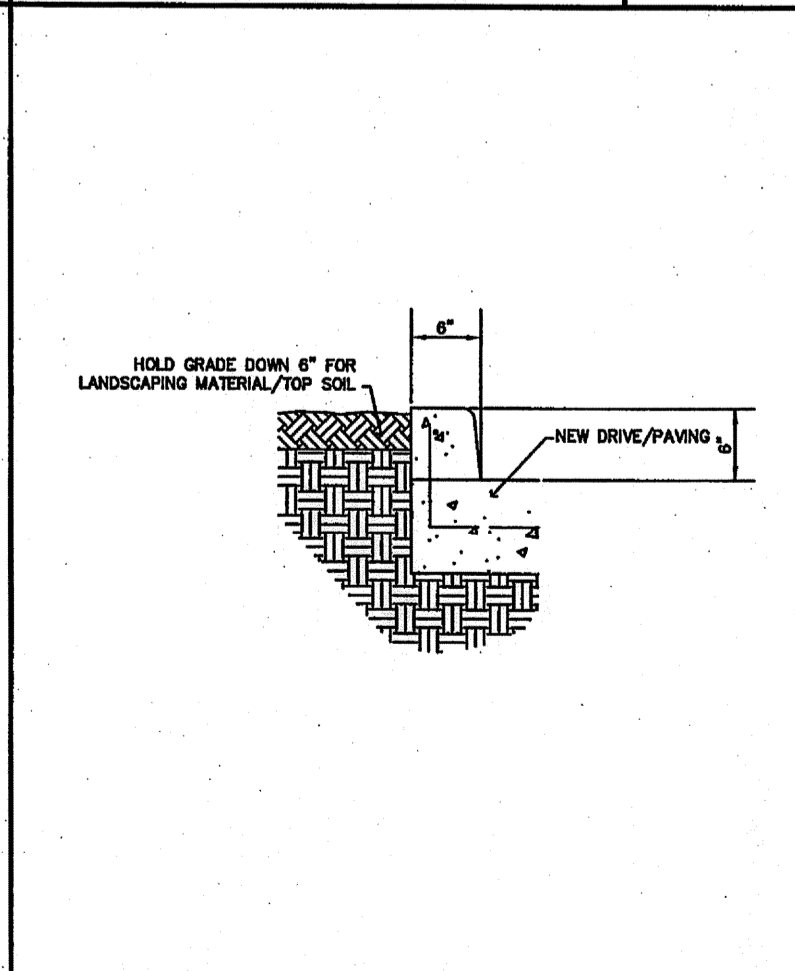
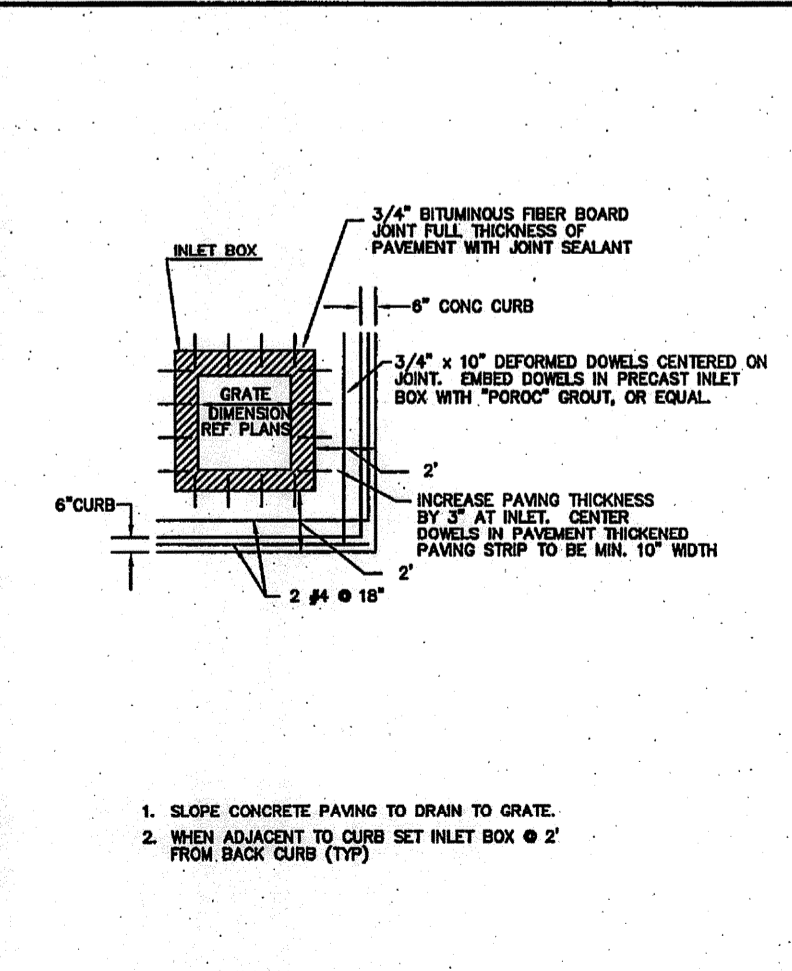
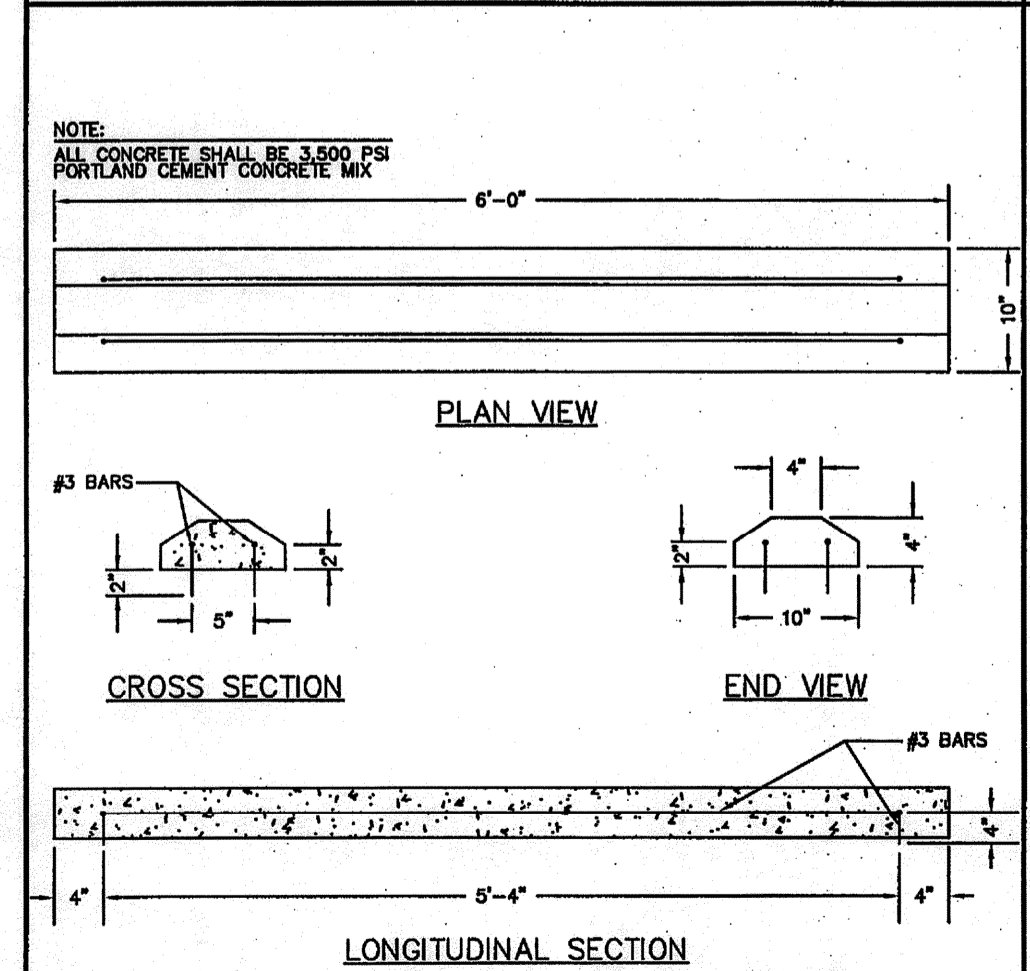

WHEEL STOP DETAIL No. 144 GRATE INLET JOINT & CURB DETAIL No. 143

TYPICAL CURB @ LANDSCAPING No. 138 JOINT SEALANT FOR CONC. PAVEMENT No. 134

PAVING EXP. JOINT INTERSECTION No. 130 TYPICAL HANDICAP PARKING DETAIL No. 105

Kevin Polasek, P.E.
 STATE OF TEXAS
 KEVIN POLASEK
 98632
 PROFESSIONAL ENGINEER
 THE SEAL APPEARING ON THIS DOCUMENT WAS AUTHORIZED BY KEVIN POLASEK, P.E. 98632 ON 11/5/2008

REVNO.	DESCRIPTION	DATE	APP.
DISCOUNT TIRE (DISTRIBUTION) HOUSTON - WILLOWBROOK			
SITE PAVING DETAILS			
TERRA ASSOCIATES INC.		3000 WILCREST - SUITE 200 HOUSTON, TEXAS ZIP 77042 PHONE: 713-993-0333 FAX: 713-993-0743	
DRAWN BY: DAB	SCALE: N.T.S.	CONTRACT: 1	
CHECKED BY: KBP	DATE: NOVEMBER 2008	PROJECT No. 0280-0708	
FILE NAME: C13-PAV DET.DWG	PLOT SCALE: 1:1	SHEET C13 OF 15	